

Cable Glands for „Hazardous Areas“

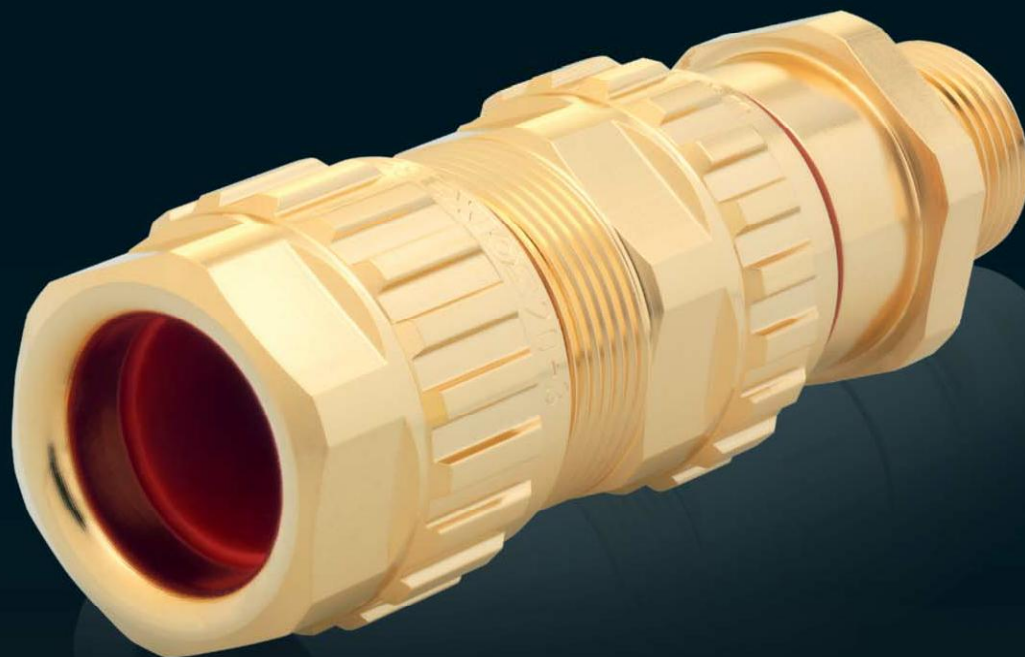

EXIOS

Cable Glands for „Hazardous Areas“



EXIOS





HUMMEL AG



For over 60 years HUMMEL AG has provided outstanding solutions for all forms of cable management applications in the form of cable glands, metal circular connectors and box enclosures. Our NEW innovative EXIOS range of Ex d cable glands now offers the highest quality, reliability, ease of installation and above all safety for all hazardous area applications by meeting the very latest ATEX / IECEx Standards.

HUMMEL AG continues to invest in its ongoing programme of Ex product development to provide its customers with the best product and safety features – We aim to meet our Company motto:

HUMMEL AG has a worldwide reputation as a leading manufacturer of electro-mechanical devices and offers the latest construction, tool making, plating, and assembly within our automated factory processes. Our staffs are trained to the highest standards.

EXIOS should be the new choice of specification

Used primarily on Offshore / Onshore Oil & Gas Exploration the EXIOS is gaining rapid global recognition as the leading Ex Gland for Dual Seal and Barrier applications. Together with the existing high specification of our premier brand – HSK – HUMMEL can offer cable glands for Exd / Exe / Exi areas in V0 rated plastic, brass, nickel plated, stainless steel. Linked to these items are our approved range of cable gland accessories.

HUMMEL AG offers its customer base the Global Coverage demanded with point of contact in most continents. See the HUMMEL website for our locations and network of sales agents and distributors. Quality Management is fundamental to our approach and EXIOS is produced to ISO 9001:2008 and the very latest flameproof standards globally.

EXIOS IS THE NUMBER ONE CHOICE FOR ALL Ex d CABLE GLANDS



General:

The quality of our products has been certified by many different certification bodies and authorities. HUMMEL AG is a certified manufacturer and supplier of electro-mechanical devices.



What is an explosion?

So that an explosion can occur, three conditions must be fulfilled; see the explosion triangle diagramm.

1. Fuel
2. Oxygen
3. Source of ignition

If one removes one of these three conditions, an explosion cannot occur.

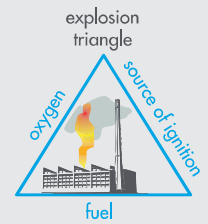

Potentially Explosive Atmosphere

A potentially explosive atmosphere is understood to be a mixture of a combustible material and oxygen. Oxygen is generally present as a component of air. Combustible materials can be e.g.: gases, fluids, vapours, mist or dusts. If the proportion of oxygen falls below a certain value dependent on the material, known as the oxygen limit concentration, then this mixture cannot be ignited.

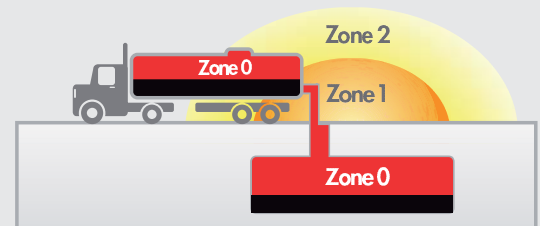
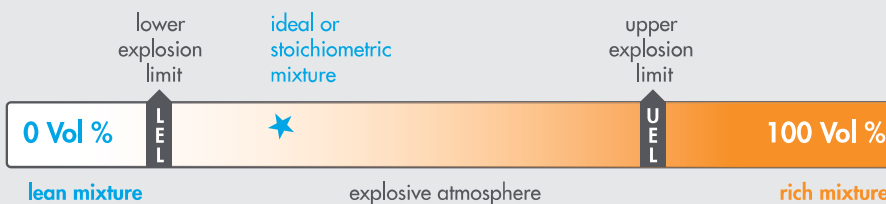

Zones IEC/CENELEC/ATEX

GAS	
Zone 0	relates to areas in which a potentially explosive atmosphere consisting of a mixture of air and gases, vapours or mist exists continuously, for long periods or frequently
Zone 1	relates to areas in which it can be considered that a potentially explosive atmosphere of gases, vapours or mist occurs occasionally
Zone 2	relates to areas in which it is unlikely that a potentially explosive atmosphere of gases, vapours or mist might occur, but if it does occur then in all probability only seldom and for a short period
DUST	
Zone 20	relates to areas in which a potentially explosive atmosphere consisting of a mixture of dust and air exists continuously, for long periods or frequently
Zone 21	relates to areas in which it can be considered that a potentially explosive atmosphere of a mixture of dust and air occurs occasionally
Zone 22	(note the difference between conductive and non-conductive dust!) relates to areas in which it is unlikely that a potentially explosive atmosphere of suspended dust might occur, but if it does occur then in all probability only seldom and for a short period

Zones IEC/CENELEC/ATEX

Group I Mining

- M1 high degree of safety EPL Ma
- M2 high degree of safety EPL Mb

Group II Non-Mining

- 1 very high degree of safety
 - Gas (Zone 0, 1, 2) EPL Ga
 - Dust (Zone 20, 21, 22) EPL Da
- 2 high degree of safety
 - Gas (Zone 1, 2) EPL Gb
 - Dust (Zone 21, 22) EPL Db
- 3 normal degree of safety
 - Gas (Zone 2) EPL Gc
 - Dust (Zone 22) EPL Dc

Gases and Dust

Gas		Dust	
IIA	Propane	IIIA	combustible dust
IIB	Ethylene	IIIB	non-conductive dust
IIC	Hydrogene	IIIC	conductive dust

Temperatur Classes

Temperature class	Highest permissible surface temperature of the operating facility	Ignition temperature of combustible materials
T1	450 °C	>450 °C
T2	300 °C	>300 °C <450 °C
T3	200 °C	>200 °C <300 °C
T4	135 °C	>135 °C <200 °C
T5	100 °C	>100 °C <200 °C
T6	85 °C	> 85 °C <100 °C

Protection Concepts

Electrical

Intrinsic safety	Ex ia	IEC 60079-11/EN 60079-11	Zone 0,1,2	Limit the energy	
Intrinsic safety	Ex ib	IEC 60079-11/EN 60079-11	Zone 1,2		
Intrinsic safety	Ex ic	IEC 60079-11/EN 60079-11	Zone 2		
Increased safety	Ex e	IEC 60079-7/EN 60079-7	Zone 1,2	No arcs, sparks or hot surfaces, IP54 or better.	
Flameproof enclosure	Ex d	IEC 60079-1/EN 60079-1	Zone 1,2	Contain the explosion Use a flamepath.	

Dust Protection

Enclosure	Ex t	IEC 60079-31/EN 60079-31	Zone 20,21,22	Dust tight enclosure IP6X	
-----------	------	--------------------------	---------------	---------------------------	--

International Protection, EN 60529

1. Code		2. Code	Penetration of water									
			Non-protected	protection against drip water (or dripping water)	Protected against vertically falling water drops when device is tilted up to 15°	Water sprayed at an angle up to 60° on either side of the vertical shall have no harmful effects	Water splashed from any direction shall have no harmful effects	Water projected in jets from any direction shall have no harmful effects	Water projected in powerful jets from any direction shall have no harmful effects	protection against temporary submersion	protection against permanent submersion	
Protection against human access to hazardous parts	Protection of equipment against penetration of solid foreign objects		IP 00	IP x1	IP x2	IP x3	IP x4	IP x5	IP x6	IP x7	IP x8	
Non-protected	Non-protected	IP 0x	IP 00									
Protected against access to hazardous parts with the back of the hand	Protected against solid foreign objects larger in diameter than 50mm	IP 1x	IP 10	IP 11	IP 12							
Protected against access to hazardous parts with a finger	Protected against solid foreign object larger in diameter than 12,5mm	IP 2x	IP 20	IP 21	IP 22	IP 23						
Protected against access to hazardous parts with a tool larger in diameter than 25mm	Protected against solid foreign objects larger in diameter than 2,5mm	IP 3x	IP 30	IP 31	IP 32	IP 33	IP 34					
Protected against access to hazardous parts with a wire larger in diameter than 1,0mm	Protected against solid foreign objects larger in diameter than 1mm	IP 4x	IP 40	IP 41	IP 42	IP 43	IP 44					
Protected against access to hazardous parts with a wire larger in diameter than 1,0mm	Prevents penetration of dust sufficient to cause damage inside the equipment.	IP 5x	IP 50				IP 54	IP 55				
Protected against access to hazardous parts with a wire larger in diameter than 1,0mm	Dust proof	IP 6x	IP 60					IP 65	IP 66	IP 67	IP 68	

Standards

IEC 60079-0:2011

IEC 60079-1:2014

IEC 60079-7:2006-07

IEC 60079-31:2013

EN 60079-0:2012

EN 60079-1:2014

EN 60079-7:2007

EN 60079-31:2014

EN 60529

EXIOS

+ STANDARD

- Dual seal on the inner and outer sheath of the cable
- Time-proven HUMMEL clamping system
- Armour acceptance range from 0 – 2,5 mm
- Exceptional clamping range
- Innovative „Interlocking Armour Cone“
- Zero torsion on cable cores and armour
- Fast and easy pre-assembly by hand by the use of profile material with maximum grip

- According to the latest IECEx and ATEX standards
- Ex e / Ex d / Ex ta
- Zones 1, 2, 20, 21, 22
- II 2G Ex d e IIC Gb / II 1D Ex ta IIIC Da
- Equipment Protection Level GbDa

- IP 66, 67 and 68 (5 bar)
- Halogen- and phosphorous-free
- Silicone Seals and O-Ring are standard

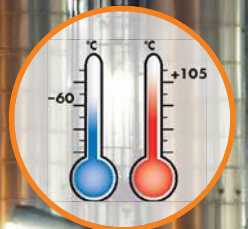
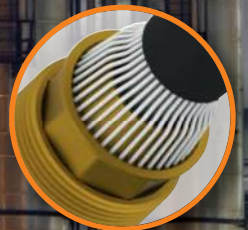

Type: EXIOS Standard	Materials and Technical Data
Material	brass, stainless steel on request
Seals / O-Rings	silicone, VMQ
Clamping insert	PA 6
Armour	Metallic Armour or Screen
Temperature Range	-60° C – 105° C (-76 °F – 221 °F)
Protection	IP 66, 67 and 68 (5 bar)
Certificate	IECEX BVS 10.0078 X BVS 10 ATEX E 062 X CSA 2557737

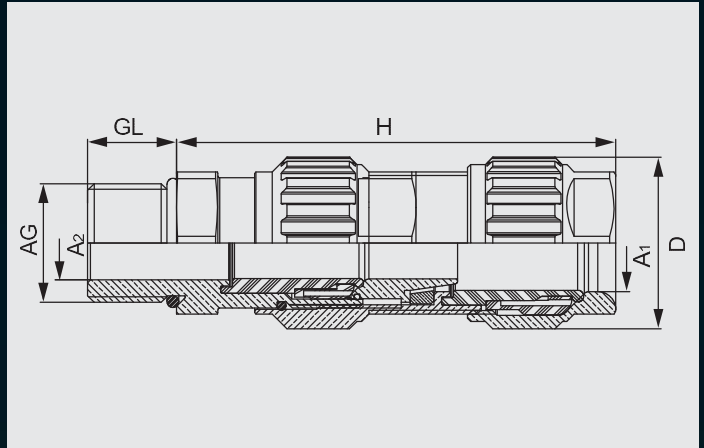

Metric brass

Number	Gland Size	AG	ϕ mm	D mm	H max.	GL mm	∅ A1 mm	∅ A2 mm	Armour ∅ k mm		
									Clamping ring 1	Clamping ring 2	Ring3 optional
1.605.1600.50	20 – 1	M16x1,5	22	27	69,5	16	6 – 12	3 – 8,1	0 – 0,7	0,7 – 1,25	–
1.605.2000.50	20 – 1	M20x1,5	22	27	69,5	16	6 – 12	3 – 8,1	0 – 0,7	0,7 – 1,25	–
1.605.2000.51	20 – 2	M20x1,5	24	29	74,3	16	9 – 16	6 – 12	0 – 0,7	0,7 – 1,25	–
1.605.2000.52	20 – 3	M20x1,5	30	35	80,5	16	12,5 – 20,5	9 – 14	0 – 0,7	0,7 – 1,4	–
1.605.2500.51	20 – 3	M25x1,5	30	35	80,5	16	12,5 – 20,5	9 – 14	0 – 0,7	0,7 – 1,4	–
1.605.2500.50	25	M25x1,5	36	42	91	16	16,9 – 26	12,5 – 20,5	0 – 0,7	0,9 – 1,6	0,7 – 1,4
1.605.3200.50	32	M32x1,5	46	52	96	16	22 – 33	16,9 – 26	0 – 0,7	1,3 – 2,0	0,7 – 1,4
1.605.4000.50	40	M40x1,5	55	64	107	16	28 – 41	22 – 33	0 – 0,7	1,3 – 2,0	0,7 – 1,4
1.605.5000.50	50	M50x1,5	65	73	131,5	16	36 – 52,6	28,9 – 44,4	0 – 1,0	1,5 – 2,5	1,0 – 2,0
1.605.6300.50	63	M63x1,5	80	90	144,5	16	46 – 65,3	39,9 – 56,3	0 – 1,0	1,5 – 2,5	1,0 – 2,0
1.605.7500.50	75	M75x1,5	95	107	154	16	57 – 78	50,5 – 68,2	0 – 1,0	1,5 – 2,5	1,0 – 2,0

NPT brass

Number	Gland Size	AG	ϕ mm	D mm	H max.	GL mm	∅ A1 mm	∅ A2 mm	Armour ∅ k mm		
									Clamping ring 1	Clamping ring 2	Ring3 optional
1.605.3800.70	20 – 1	NPT 3/8"	22	27	69,5	16	6 – 12	3 – 8,1	0 – 0,7	0,7 – 1,25	–
1.605.1200.70	20 – 2	NPT 1/2"	24	29	74,3	20	9 – 16	6 – 12	0 – 0,7	0,7 – 1,25	–
1.605.1200.71	20 – 3	NPT 1/2"	30	35	80,5	20	12,5 – 20,5	9 – 14	0 – 0,7	0,7 – 1,4	–
1.605.3400.70	25	NPT 3/4"	36	42	91	20,5	16,9 – 26	12,5 – 20,5	0 – 0,7	0,9 – 1,6	0,7 – 1,4
1.605.1000.70	32	NPT 1"	46	52	96	25	22 – 33	16,9 – 26	0 – 0,7	1,3 – 2,0	0,7 – 1,4
1.605.5400.70	40	NPT 1 1/4"	55	64	107	26	28 – 41	22 – 33	0 – 0,7	1,3 – 2,0	0,7 – 1,4
1.605.6400.70	40	NPT 1 1/2"	55	64	107	26,5	28 – 41	22 – 33	0 – 0,7	1,3 – 2,0	0,7 – 1,4
1.605.2000.70	50	NPT 2"	65	73	131,5	27	36 – 52,6	28,9 – 44,4	0 – 1,0	1,5 – 2,5	1,0 – 2,0
1.605.5200.70	63	NPT 2 1/2"	80	90	144,5	40	46 – 65,3	39,9 – 56,3	0 – 1,0	1,5 – 2,5	1,0 – 2,0
1.605.3000.70	75	NPT 3"	95	107	154	41,5	57 – 78	50,5 – 68,2	0 – 1,0	1,5 – 2,5	1,0 – 2,0

EXIOS

+ STANDARD

- Dual seal on the inner and outer sheath of the cable
- Time-proven HUMMEL clamping system
- Armour acceptance range from 0 – 2,5 mm
- Exceptional clamping range
- Innovative „Interlocking Armour Cone“
- Zero torsion on cable cores and armour
- Fast and easy pre-assembly by hand by the use of profile material with maximum grip
- According to the latest IECEx and ATEX standards
- Ex e / Ex d / Ex ta
- Zones 1, 2, 20, 21, 22
- II 2G Ex d e IIC Gb / II 1D Ex ta IIIC Da
- Equipment Protection Level GbDa
- IP 66, 67 and 68 (5 bar)
- Halogen- and phosphorous-free
- Silicone Seals and O-Ring are standard



ATEX

ABS



ERC

kti



Type: EXIOS Standard	Materials and Technical Data
Material	nickel-plated brass
Seals / O-Rings	silicone, VMQ
Clamping insert	PA 6
Armour	Metallic Armour or Screen
Temperature Range	-60° C – 105° C (-76 °F – 221 °F)
Protection	IP 66, 67 and 68 (5 bar)
Certificate	IECEX BVS 10.0078 X BVS 10 ATEX E 062 X CSA 2557737

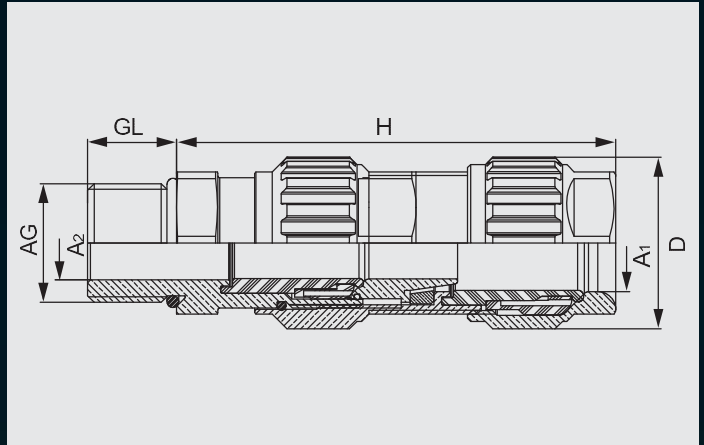

Metric nickel plated brass

Number	Gland Size	AG	ϕ mm	D mm	H max.	GL mm	∅ A1 mm	∅ A2 mm	Armour ∅k mm		
									Clamping ring 1	Clamping ring 2	Ring3 optional
1.605.1603.50	20 – 1	M16x1,5	22	27	69,5	16	6 – 12	3 – 8,1	0 – 0,7	0,7 – 1,25	–
1.605.2003.50	20 – 1	M20x1,5	22	27	69,5	16	6 – 12	3 – 8,1	0 – 0,7	0,7 – 1,25	–
1.605.2003.51	20 – 2	M20x1,5	24	29	74,3	16	9 – 16	6 – 12	0 – 0,7	0,7 – 1,25	–
1.605.2003.52	20 – 3	M20x1,5	30	35	80,5	16	12,5 – 20,5	9 – 14	0 – 0,7	0,7 – 1,4	–
1.605.2503.51	20 – 3	M25x1,5	30	35	80,5	16	12,5 – 20,5	9 – 14	0 – 0,7	0,7 – 1,4	–
1.605.2503.50	25	M25x1,5	36	42	91	16	16,9 – 26	12,5 – 20,5	0 – 0,7	0,9 – 1,6	0,7 – 1,4
1.605.3203.50	32	M32x1,5	46	52	96	16	22 – 33	16,9 – 26	0 – 0,7	1,3 – 2,0	0,7 – 1,4
1.605.4003.50	40	M40x1,5	55	64	107	16	28 – 41	22 – 33	0 – 0,7	1,3 – 2,0	0,7 – 1,4
1.605.5003.50	50	M50x1,5	65	73	131,5	16	36 – 52,6	28,9 – 44,4	0 – 1,0	1,5 – 2,5	1,0 – 2,0
1.605.6303.50	63	M63x1,5	80	90	144,5	16	46 – 65,3	39,9 – 56,3	0 – 1,0	1,5 – 2,5	1,0 – 2,0
1.605.7503.50	75	M75x1,5	95	107	154	16	57 – 78	50,5 – 68,2	0 – 1,0	1,5 – 2,5	1,0 – 2,0

NPT nickel plated brass

Number	Gland Size	AG	ϕ mm	D mm	H max.	GL mm	∅ A1 mm	∅ A2 mm	Armour ∅k mm		
									Clamping ring 1	Clamping ring 2	Ring3 optional
1.605.3803.70	20 – 1	NPT 3/8"	22	27	69,5	16	6 – 12	3 – 8,1	0 – 0,7	0,7 – 1,25	–
1.605.1203.70	20 – 2	NPT 1/2"	24	29	74,3	20	9 – 16	6 – 12	0 – 0,7	0,7 – 1,25	–
1.605.1203.71	20 – 3	NPT 1/2"	30	35	80,5	20	12,5 – 20,5	9 – 14	0 – 0,7	0,7 – 1,4	–
1.605.3403.70	25	NPT 3/4"	36	42	91	20,5	16,9 – 26	12,5 – 20,5	0 – 0,7	0,9 – 1,6	0,7 – 1,4
1.605.1003.70	32	NPT 1"	46	52	96	25	22 – 33	16,9 – 26	0 – 0,7	1,3 – 2,0	0,7 – 1,4
1.605.5403.70	40	NPT 1 1/4"	55	64	107	26	28 – 41	22 – 33	0 – 0,7	1,3 – 2,0	0,7 – 1,4
1.605.6403.70	40	NPT 1 1/2"	55	64	107	26,5	28 – 41	22 – 33	0 – 0,7	1,3 – 2,0	0,7 – 1,4
1.605.2003.70	50	NPT 2"	65	73	131,5	27	36 – 52,6	28,9 – 44,4	0 – 1,0	1,5 – 2,5	1,0 – 2,0
1.605.5203.70	63	NPT 2 1/2"	80	90	144,5	40	46 – 65,3	39,9 – 56,3	0 – 1,0	1,5 – 2,5	1,0 – 2,0
1.605.3003.70	75	NPT 3"	95	107	154	41,5	57 – 78	50,5 – 68,2	0 – 1,0	1,5 – 2,5	1,0 – 2,0

EXIOS

+ BARRIER

The innovative and advanced design of the EXIOS is available as a barrier version.

The EXIOS Barrier has all the outstanding EXIOS features, but uses a compound barrier to make it flameproof. Whenever installation requires a barrier gland, EXIOS Barrier is your solution.

- According to the latest IECEx and ATEX standards
- Ex e / Ex d / Ex ta
- Zones 1, 2, 20, 21, 22
- I M2 Ex d e I Mb IIC Gb / Ex ta IIC Da
- Equipment Protection Level MbGbDa

- IP 66, 67 and 68 (5 bar)
- Halogen- and phosphorous-free
- Silicone Seals and O-Ring are standard



ATEX

ABS



ERC

ktl



Type: EXIOS BARRIER	Materials and Technical Data
Material	brass, stainless steel on request
Seals / O-Rings	silicone, VMQ
Compound	Epoxy-Putty
Clamping insert	PA 6
Armour	Metallic Armour or Screen
Temperature Range	-60° C – 85° C (-76 °F – 185 °F)
Protection	IP 66, 67 and 68 (5 bar)
Certificate	IECEx SIR 11.0044X Sira 11 ATEX 1110X CSA 2557737

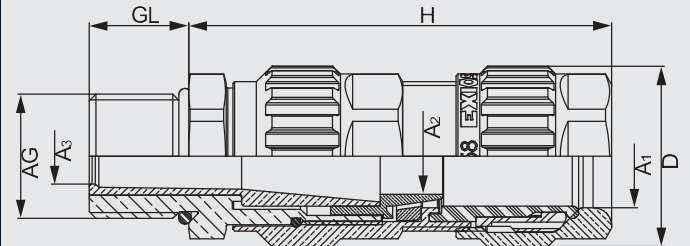

Metric brass

Number	Gland Size	AG	ϕ mm	D mm	H max.	GL mm	∅ A1 mm	∅ A2 max. inner sheath	∅ A3 max. over cores	Armour ∅ mm		
										max. No. cores	Clamping ring 1	Clamping ring 2
1.606.1600.50	20 – 1	M16x1,5	22	27	69,5	16	6 – 12	8,2	7,9	8	0 – 0,7	0,7 – 1,25
1.606.2000.50	20 – 1	M20x1,5	22	27	69,5	16	6 – 12	8,2	7,9	8	0 – 0,7	0,7 – 1,25
1.606.2000.51	20 – 2	M20x1,5	24	29	74,3	16	9 – 16	12	8,8	10	0 – 0,7	0,7 – 1,25
1.606.2000.52	20 – 3	M20x1,5	30	35	80,5	16	12,5 – 20,5	14	11,5	15	0 – 0,7	0,7 – 1,4
1.606.2500.51	20 – 3	M25x1,5	30	35	80,5	16	12,5 – 20,5	14	11,5	15	0 – 0,7	0,7 – 1,4
1.606.2500.50	25	M25x1,5	36	42	91	16	16,9 – 26	20	16,4	25	0 – 0,7	0,9 – 1,6
1.606.3200.50	32	M32x1,5	46	52	96	16	22 – 33	26	21,4	45	0 – 0,7	1,3 – 2,0
1.606.4000.50	40	M40x1,5	55	64	107	16	28 – 41	33,2	27,6	70	0 – 0,7	1,3 – 2,0
1.606.5000.50	50	M50x1,5	65	73	131,5	16	36 – 52,6	44,2	37,5	85	0 – 1,0	1,5 – 2,5
1.606.6300.50	63	M63x1,5	80	90	144,5	16	46 – 65,3	56,2	47,3	120	0 – 1,0	1,5 – 2,5
1.606.7500.50	75	M75x1,5	95	107	154	16	57 – 78	68,2	58	150	0 – 1,0	1,5 – 2,5

NPT brass

Number	Gland Size	AG	ϕ mm	D mm	H max.	GL mm	∅ A1 mm	∅ A2 max. inner sheath	∅ A3 max. over cores	Armour ∅ mm		
										max. No. cores	Clamping ring 1	Clamping ring 2
1.606.3800.70	20 – 1	NPT 3/8"	22	27	64,0	16	6 – 12	8,2	7,9	8	0 – 0,7	0,7 – 1,25
1.606.1200.70	20 – 2	NPT 1/2"	24	29	68,0	20	9 – 16	12	8,8	10	0 – 0,7	0,7 – 1,25
1.606.1200.71	20 – 3	NPT 1/2"	30	35	73,0	20	12,5 – 20,5	14	11,5	15	0 – 0,7	0,7 – 1,4
1.606.3400.70	25	NPT 3/4"	36	42	81,3	20,5	16,9 – 26	20	16,4	25	0 – 0,7	0,9 – 1,6
1.606.1000.70	32	NPT 1"	46	52	85,5	25	22 – 33	26	21,4	45	0 – 0,7	1,3 – 2,0
1.606.5400.70	40	NPT 1 1/4"	55	64	94,4	26	28 – 41	33,2	27,6	70	0 – 0,7	1,3 – 2,0
1.606.6400.70	40	NPT 1 1/2"	55	64	94,4	26,5	28 – 41	33,2	27,6	70	0 – 0,7	1,3 – 2,0
1.606.2000.70	50	NPT 2"	65	73	116,3	27	36 – 52,6	44,2	37,5	85	0 – 1,0	1,5 – 2,5
1.606.5200.70	63	NPT 2 1/2"	80	90	127,6	40	46 – 65,3	56,2	47,3	120	0 – 1,0	1,5 – 2,5
1.606.3000.70	75	NPT 3"	95	107	136,5	41,5	57 – 78	68,2	58	150	0 – 1,0	1,5 – 2,5

EXIOS

+ BARRIER

The innovative and advanced design of the EXIOS is available as a barrier version.

The EXIOS Barrier has all the outstanding EXIOS features, but uses a compound barrier to make it flameproof. Whenever installation requires a barrier gland, EXIOS Barrier is your solution.

- According to the latest IECEx and ATEX standards
- Ex e / Ex d / Ex ta
- Zones 1, 2, 20, 21, 22
- I M2 Ex d e I Mb IIC Gb / Ex ta IIC Da
- Equipment Protection Level MbGbDa

- IP 66, 67 and 68 (5 bar)
- Halogen- and phosphorous-free
- Silicone Seals and O-Ring are standard

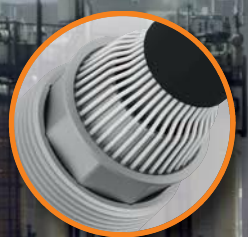

Type: EXIOS BARRIER	Materials and Technical Data
Material	nickel-plated brass
Seals / O-Rings	silicone, VMQ
Compound	Epoxy-Putty
Clamping insert	PA 6
Armour	Metallic Armour or Screen
Temperature Range	-60° C – 85° C (-76 °F – 185 °F)
Protection	IP 66, 67 and 68 (5 bar)
Certificate	IECEx SIR 11.0044X Sira 11 ATEX 1110X CSA 2557737

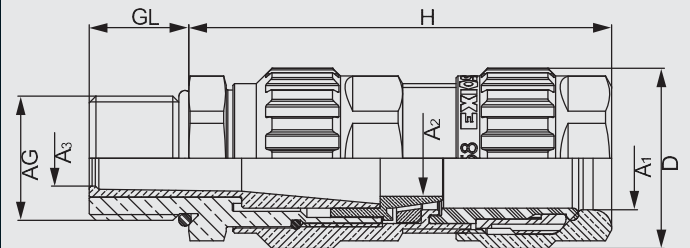

Metric nickel plated brass

Number	Gland Size	AG	ϕ mm	D mm	H max.	GL mm	∅ A1 mm	∅ A2 max. inner sheath	∅ A3 max. over cores	Armour ∅ mm		
										max. No. cores	Clamping ring 1	Clamping ring 2
1.606.1603.50	20 – 1	M16x1,5	22	27	69,5	16	6 – 12	8,2	7,9	8	0 – 0,7	0,7 – 1,25
1.606.2003.50	20 – 1	M20x1,5	22	27	69,5	16	6 – 12	8,2	7,9	8	0 – 0,7	0,7 – 1,25
1.606.2003.51	20 – 2	M20x1,5	24	29	74,3	16	9 – 16	12	8,8	10	0 – 0,7	0,7 – 1,25
1.606.2003.52	20 – 3	M20x1,5	30	35	80,5	16	12,5 – 20,5	14	11,5	15	0 – 0,7	0,7 – 1,4
1.606.2503.51	20 – 3	M25x1,5	30	35	80,5	16	12,5 – 20,5	14	11,5	15	0 – 0,7	0,7 – 1,4
1.606.2503.50	25	M25x1,5	36	42	91	16	16,9 – 26	20	16,4	25	0 – 0,7	0,9 – 1,6
1.606.3203.50	32	M32x1,5	46	52	96	16	22 – 33	26	21,4	45	0 – 0,7	1,3 – 2,0
1.606.4003.50	40	M40x1,5	55	64	107	16	28 – 41	33,2	27,6	70	0 – 0,7	1,3 – 2,0
1.606.5003.50	50	M50x1,5	65	73	131,5	16	36 – 52,6	44,2	37,5	85	0 – 1,0	1,5 – 2,5
1.606.6303.50	63	M63x1,5	80	90	144,5	16	46 – 65,3	56,2	47,3	120	0 – 1,0	1,5 – 2,5
1.606.7503.50	75	M75x1,5	95	107	154	16	57 – 78	68,2	58	150	0 – 1,0	1,5 – 2,5

NPT nickel plated brass

Number	Gland Size	AG	ϕ mm	D mm	H max.	GL mm	∅ A1 mm	∅ A2 max. inner sheath	∅ A3 max. over cores	Armour ∅ mm		
										max. No. cores	Clamping ring 1	Clamping ring 2
1.606.3803.70	20 – 1	NPT 3/8"	22	27	64,0	16	6 – 12	8,2	7,9	8	0 – 0,7	0,7 – 1,25
1.606.1203.70	20 – 2	NPT 1/2"	24	29	68,0	20	9 – 16	12	8,8	10	0 – 0,7	0,7 – 1,25
1.606.1203.71	20 – 3	NPT 1/2"	30	35	73,0	20	12,5 – 20,5	14	11,5	15	0 – 0,7	0,7 – 1,4
1.606.3403.70	25	NPT 3/4"	36	42	81,3	20,5	16,9 – 26	20	16,4	25	0 – 0,7	0,9 – 1,6
1.606.1003.70	32	NPT 1"	46	52	85,5	25	22 – 33	26	21,4	45	0 – 0,7	1,3 – 2,0
1.606.5403.70	40	NPT 1 1/4"	55	64	94,4	26	28 – 41	33,2	27,6	70	0 – 0,7	1,3 – 2,0
1.606.6403.70	40	NPT 1 1/2"	55	64	94,4	26,5	28 – 41	33,2	27,6	70	0 – 0,7	1,3 – 2,0
1.606.2003.70	50	NPT 2"	65	73	116,3	27	36 – 52,6	44,2	37,5	85	0 – 1,0	1,5 – 2,5
1.606.5203.70	63	NPT 2 1/2"	80	90	127,6	40	46 – 65,3	56,2	47,3	120	0 – 1,0	1,5 – 2,5
1.606.3003.70	75	NPT 3"	95	107	136,5	41,5	57 – 78	68,2	58	150	0 – 1,0	1,5 – 2,5

EXIOS

+ A2F

With the EXIOS A2F, HUMMEL follows the successful design of the EXIOS range of cable glands. This model is especially designed for unarmoured and braided cables where durability and quality is a must.

The EXIOS A2F incorporates the time-proven HUMMEL clamping system, which offers a large clamping range in a small gland size. Therefore a smaller gland size can often be used.

- According to the latest IECEx and ATEX standards
- Ex e / Ex d / Ex ta
- Zones 1, 2, 20, 21, 22
- II 2G Ex d e IIC Gb / II 1D Ex ta IIIC Da
- Equipment Protection Level GbDa

- IP 66, 67 and 68 (5 bar)
- Halogen- and phosphorous-free
- Silicone Seals and O-Ring are standard

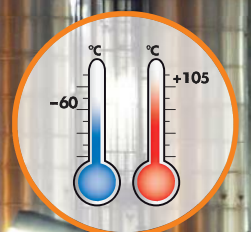

ATEX

ABS



EAC



kcl

Type: EXIOS A2F	Materials and Technical Data
Material	brass, stainless steel on request
Seals / O-Rings	silicone, VMQ
Clamping insert	PA 6
Temperature Range	-60° C – 105° C (-76 °F – 221 °F)
Protection	IP 66, 67 and 68 (5 bar)
Certificate	IECEX DEK 12.0039X DEKRA 12 ATEX 0139X CSA 2557737

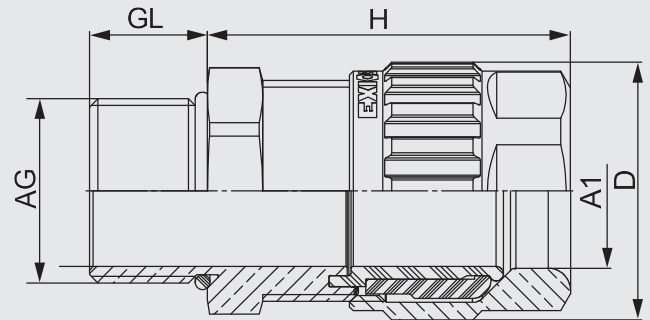

Metric brass

Number	Gland Size	AG	Φ mm	D mm	H max.	GL mm	∅ A1 mm
1.608.1600.50	20 – 1	M16x1,5	22	27	35,6	16	6 – 12
1.608.2000.50	20 – 1	M20x1,5	22	27	35,6	16	6 – 12
1.608.2000.51	20 – 2	M20x1,5	24	29	39,7	16	9 – 16
1.608.2500.50	20 – 3	M25x1,5	30	35	47,5	16	12,5 – 20,5
1.608.3200.50	25	M32x1,5	36	42	47,8	16	16,9 – 26
1.608.4000.50	32	M40x1,5	46	52	51,1	16	22 – 33
1.608.5000.50	40	M50x1,5	55	64	56,8	16	28 – 41
1.608.6300.50	50	M63x1,5	65	73	65,4	16	40 – 52,6
1.608.7500.50	63	M75x1,5	80	90	70,3	16	51 – 65,3
1.608.9000.50	75	M90x2,0	95	107	76,2	20	62 – 78

NPT brass

Number	Gland Size	AG	Φ mm	D mm	H max.	GL mm	∅ A1 mm
1.608.3800.70	20 – 1	NPT 3/8"	22	27	35,6	16	6 – 12
1.608.1200.70	20 – 1	NPT 1/2"	22/24	27	35,6	20	6 – 12
1.608.1200.71	20 – 2	NPT 1/2"	24	29	39,7	20	9 – 16
1.608.3400.70	20 – 3	NPT 3/4"	30	35	47,5	20,5	12,5 – 20,5
1.608.1000.70	25	NPT 1"	36	42	47,8	25	16,9 – 26
1.608.5400.70	32	NPT 1 1/4"	46	52	51,1	26	22 – 33
1.608.6400.70	40	NPT 1 1/2"	55	64	56,8	26,5	28 – 41
1.608.2000.70	50	NPT 2"	65	73	65,4	27	40 – 52,6
1.608.5200.70	63	NPT 2 1/2"	80	90	70,3	40	51 – 61
1.608.3000.70	75	NPT 3"	95	107	76,2	41,5	62 – 78

EXIOS

+ A2F

With the EXIOS A2F, HUMMEL follows the successful design of the EXIOS range of cable glands. This model is especially designed for unarmoured and braided cables where durability and quality is a must.

The EXIOS A2F incorporates the time-proven HUMMEL clamping system, which offers a large clamping range in a small gland size. Therefore a smaller gland size can often be used.

- According to the latest IECEx and ATEX standards
- Ex e / Ex d / Ex ta
- Zones 1, 2, 20, 21, 22
- II 2G Ex d e IIC Gb / II 1D Ex ta IIIC Da
- Equipment Protection Level GbDa

- IP 66, 67 and 68 (5 bar)
- Halogen- and phosphorous-free
- Silicone Seals and O-Ring are standard

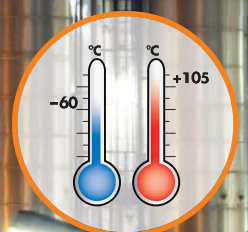

ATEX

ABS



EAC



kcl

Type: EXIOS A2F	Materials and Technical Data
Material	nickel-plated brass
Seals / O-Rings	silicone, VMQ
Clamping insert	PA 6
Temperature Range	-60° C – 105° C (-76 °F – 221 °F)
Protection	IP 66, 67 and 68 (5 bar)
Certificate	IEEx DEK 12.0039X DEKRA 12 ATEX 0139X CSA 2557737

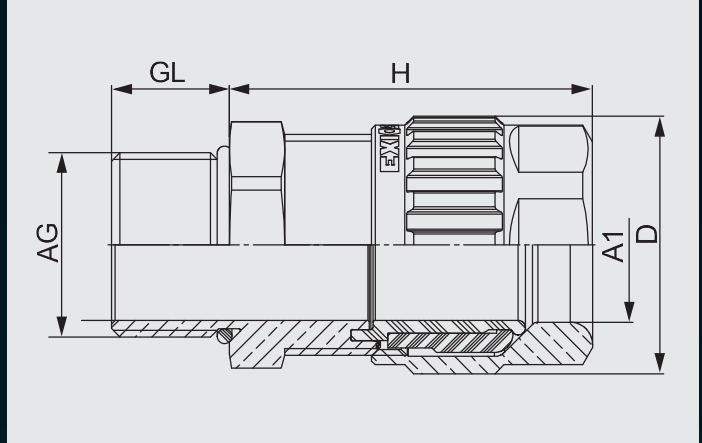

Metric nickel plated brass

Number	Gland Size	AG	Φ mm	D mm	H max.	GL mm	∅ A1 mm
1.608.1603.50	20 – 1	M16x1,5	22	27	35,6	16	6 – 12
1.608.2003.50	20 – 1	M20x1,5	22	27	35,6	16	6 – 12
1.608.2003.51	20 – 2	M20x1,5	24	29	39,7	16	9 – 16
1.608.2503.50	20 – 3	M25x1,5	30	35	47,5	16	12,5 – 20,5
1.608.3203.50	25	M32x1,5	36	42	47,8	16	16,9 – 26
1.608.4003.50	32	M40x1,5	46	52	51,1	16	22 – 33
1.608.5003.50	40	M50x1,5	55	64	56,8	16	28 – 41
1.608.6303.50	50	M63x1,5	65	73	65,4	16	40 – 52,6
1.608.7503.50	63	M75x1,5	80	90	70,3	16	51 – 65,3
1.608.9003.50	75	M90x2,0	95	107	76,2	20	62 – 78

NPT nickel plated brass

Number	Gland Size	AG	Φ mm	D mm	H max.	GL mm	∅ A1 mm
1.608.3803.70	20 – 1	NPT 3/8"	22	27	35,6	16	6 – 12
1.608.1203.70	20 – 1	NPT 1/2"	22/24	27	35,6	20	6 – 12
1.608.1203.71	20 – 2	NPT 1/2"	24	29	39,7	20	9 – 16
1.608.3403.70	20 – 3	NPT 3/4"	30	35	47,5	20,5	12,5 – 20,5
1.608.1003.70	25	NPT 1"	36	42	47,8	25	16,9 – 26
1.608.5403.70	32	NPT 1 1/4"	46	52	51,1	26	22 – 33
1.608.6403.70	40	NPT 1 1/2"	55	64	56,8	26,5	28 – 41
1.608.2003.70	50	NPT 2"	65	73	65,4	27	40 – 52,6
1.608.5203.70	63	NPT 2 1/2"	80	90	70,3	40	51 – 61
1.608.3003.70	75	NPT 3"	95	107	76,2	41,5	62 – 78

EXIOS

+ MZ

- Dual seal on the inner and outer sheath of the cable
 - Time-proven HUMMEL clamping system
 - Armour acceptance range from 0 – 2,5 mm
 - Exceptional clamping range
 - Innovative „Interlocking Armour Cone“
 - Zero torsion on cable cores and armour
 - Fast and easy pre-assembly by hand by the use of profile material with maximum grip
 - With additional cable clamp (MZ)
-
- According to the latest IECEx and ATEX standards
 - Ex e / Ex d / Ex ta
 - Zones 1, 2, 20, 21, 22
 - II 2G Ex d e IIC Gb / II 1D Ex ta IIIC Da
 - Equipment Protection Level GbDa
-
- IP 66, 67 and 68 (5 bar)
 - Halogen- and phosphorous-free
 - Silicone Seals and O-Ring are standard

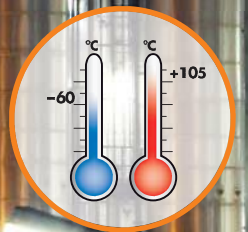
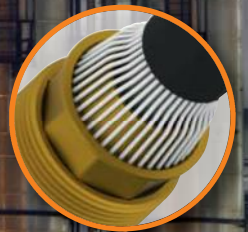

Type: EXIOS MZ	Materials and Technical Data
Material	brass, stainless steel on request
Seals / O-Rings	silicone, VMQ
Clamping insert	PA 6
Armour	Metallic Armour or Screen
Temperature Range	-60° C – 105° C (-76 °F – 221 °F)
Protection	IP 66, 67 and 68 (5 bar)
Certificate	IECEX BVS 10.0078 X BVS 10 ATEX E 062 X

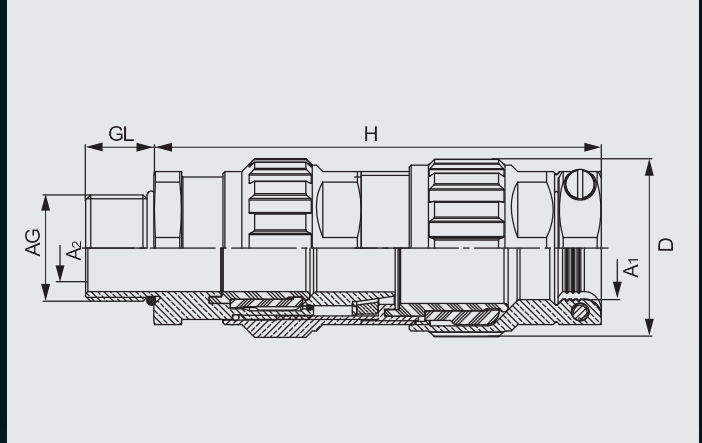

Metric brass

Number	Gland Size	AG	ϕ _H mm	D mm	H max.	GL mm	∅ _k A1 mm	∅ _k A2 mm	Armour ∅ _k mm		
									Clamping ring 1	Clamping ring 2	Ring3 optional
1.6Z5.1600.50	20 – 1	M16x1,5	22	27	79	16	6 – 11	3 – 8,1	0 – 0,7	0,7 – 1,25	–
1.6Z5.2000.50	20 – 1	M20x1,5	22	27	79	16	6 – 11	3 – 8,1	0 – 0,7	0,7 – 1,25	–
1.6Z5.2000.51	20 – 2	M20x1,5	24	29	83,8	16	9 – 13	6 – 12	0 – 0,7	0,7 – 1,25	–
1.6Z5.2000.52	20 – 3	M20x1,5	30	35	91,5	16	12,5 – 17,5	9 – 14	0 – 0,7	0,7 – 1,4	–
1.6Z5.2500.51	20 – 3	M25x1,5	30	35	91,5	16	12,5 – 17,5	9 – 14	0 – 0,7	0,7 – 1,4	–
1.6Z5.2500.50	25	M25x1,5	36	42	105,7	16	16,9 – 24	12,5 – 20,5	0 – 0,7	0,9 – 1,6	0,7 – 1,4
1.6Z5.3200.50	32	M32x1,5	46	52	107	16	22 – 32,5	16,9 – 26	0 – 0,7	1,3 – 2,0	0,7 – 1,4
1.6Z5.4000.50	40	M40x1,5	55	64	120	16	28 – 39,5	22 – 33	0 – 0,7	1,3 – 2,0	0,7 – 1,4
1.6Z5.5000.50	50	M50x1,5	65	73	144,5	16	36 – 49	28,9 – 44,4	0 – 1,0	1,5 – 2,5	1,0 – 2,0
1.6Z5.6300.50	63	M63x1,5	80	90	157,5	16	46 – 64	39,9 – 56,3	0 – 1,0	1,5 – 2,5	1,0 – 2,0
1.6Z5.7500.50	75	M75x1,5	95	107	167	16	57 – 78	50,5 – 68,2	0 – 1,0	1,5 – 2,5	1,0 – 2,0

NPT brass

Number	Gland Size	AG	ϕ _H mm	D mm	H max.	GL mm	∅ _k A1 mm	∅ _k A2 mm	Armour ∅ _k mm		
									Clamping ring 1	Clamping ring 2	Ring3 optional
1.6Z5.3800.70	20 – 1	NPT 3/8"	22	27	79	16	6 – 11	3 – 8,1	0 – 0,7	0,7 – 1,25	–
1.6Z5.1200.70	20 – 2	NPT 1/2"	24	29	83,8	20	9 – 13	6 – 12	0 – 0,7	0,7 – 1,25	–
1.6Z5.1200.71	20 – 3	NPT 1/2"	30	35	91,5	20	12,5 – 17,5	9 – 14	0 – 0,7	0,7 – 1,4	–
1.6Z5.3400.70	25	NPT 3/4"	36	42	105,7	20,5	16,9 – 24	12,5 – 20,5	0 – 0,7	0,9 – 1,6	0,7 – 1,4
1.6Z5.1000.70	32	NPT 1"	46	52	107	25	22 – 32,5	16,9 – 26	0 – 0,7	1,3 – 2,0	0,7 – 1,4
1.6Z5.5400.70	40	NPT 1 1/4"	55	64	120	26	28 – 39,5	22 – 33	0 – 0,7	1,3 – 2,0	0,7 – 1,4
1.6Z5.6400.70	40	NPT 1 1/2"	55	64	120	26,5	28 – 39,5	22 – 33	0 – 0,7	1,3 – 2,0	0,7 – 1,4
1.6Z5.2000.70	50	NPT 2"	65	73	144,5	27	36 – 49	28,9 – 44,4	0 – 1,0	1,5 – 2,5	1,0 – 2,0
1.6Z5.5200.70	63	NPT 2 1/2"	80	90	157,5	40	46 – 64	39,9 – 56,3	0 – 1,0	1,5 – 2,5	1,0 – 2,0
1.6Z5.3000.70	75	NPT 3"	95	107	167	41,5	57 – 78	50,5 – 68,2	0 – 1,0	1,5 – 2,5	1,0 – 2,0

EXIOS

+ MZ

- Dual seal on the inner and outer sheath of the cable
- Time-proven HUMMEL clamping system
- Armour acceptance range from 0 – 2,5 mm
- Exceptional clamping range
- Innovative „Interlocking Armour Cone“
- Zero torsion on cable cores and armour
- Fast and easy pre-assembly by hand by the use of profile material with maximum grip
- With additional cable clamp (MZ)
- According to the latest IECEx and ATEX standards
- Ex e / Ex d / Ex ta
- Zones 1, 2, 20, 21, 22
- II 2G Ex d e IIC Gb / II 1D Ex ta IIIC Da
- Equipment Protection Level GbDa
- IP 66, 67 and 68 (5 bar)
- Halogen- and phosphorous-free
- Silicone Seals and O-Ring are standard



Type: EXIOS MZ	Materials and Technical Data
Material	nickel-plated brass
Seals / O-Rings	silicone, VMQ
Clamping insert	PA 6
Armour	Metallic Armour or Screen
Temperature Range	-60° C – 105° C (-76 °F – 221 °F)
Protection	IP 66, 67 and 68 (5 bar)
Certificate	IECEX BVS 10.0078 X BVS 10 ATEX E 062 X

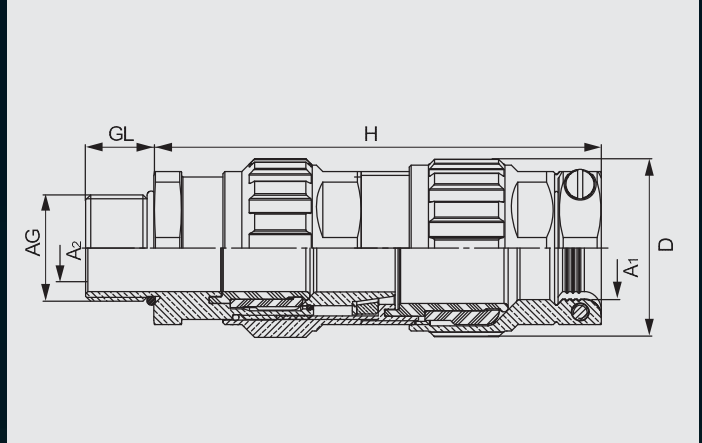

Metric nickel plated brass

Number	Gland Size	AG	ϕ mm	D mm	H max.	GL mm	∅ A1 mm	∅ A2 mm	Armour ∅ k mm		
									Clamping ring 1	Clamping ring 2	Ring3 optional
1.6Z5.1603.50	20 – 1	M16x1,5	22	27	79	16	6 – 11	3 – 8,1	0 – 0,7	0,7 – 1,25	–
1.6Z5.2003.50	20 – 1	M20x1,5	22	27	79	16	6 – 11	3 – 8,1	0 – 0,7	0,7 – 1,25	–
1.6Z5.2003.51	20 – 2	M20x1,5	24	29	83,8	16	9 – 13	6 – 12	0 – 0,7	0,7 – 1,25	–
1.6Z5.2003.52	20 – 3	M20x1,5	30	35	91,5	16	12,5 – 17,5	9 – 14	0 – 0,7	0,7 – 1,4	–
1.6Z5.2503.51	20 – 3	M25x1,5	30	35	91,5	16	12,5 – 17,5	9 – 14	0 – 0,7	0,7 – 1,4	–
1.6Z5.2503.50	25	M25x1,5	36	42	105,7	16	16,9 – 24	12,5 – 20,5	0 – 0,7	0,9 – 1,6	0,7 – 1,4
1.6Z5.3203.50	32	M32x1,5	46	52	107	16	22 – 32,5	16,9 – 26	0 – 0,7	1,3 – 2,0	0,7 – 1,4
1.6Z5.4003.50	40	M40x1,5	55	64	120	16	28 – 39,5	22 – 33	0 – 0,7	1,3 – 2,0	0,7 – 1,4
1.6Z5.5003.50	50	M50x1,5	65	73	144,5	16	36 – 49	28,9 – 44,4	0 – 1,0	1,5 – 2,5	1,0 – 2,0
1.6Z5.6303.50	63	M63x1,5	80	90	157,5	16	46 – 64	39,9 – 56,3	0 – 1,0	1,5 – 2,5	1,0 – 2,0
1.6Z5.7503.50	75	M75x1,5	95	107	167	16	57 – 78	50,5 – 68,2	0 – 1,0	1,5 – 2,5	1,0 – 2,0

NPT nickel plated brass

Number	Gland Size	AG	ϕ mm	D mm	H max.	GL mm	∅ A1 mm	∅ A2 mm	Armour ∅ k mm		
									Clamping ring 1	Clamping ring 2	Ring3 optional
1.6Z5.3803.70	20 – 1	NPT 3/8"	22	27	79	16	6 – 11	3 – 8,1	0 – 0,7	0,7 – 1,25	–
1.6Z5.1203.70	20 – 2	NPT 1/2"	24	29	83,8	20	9 – 13	6 – 12	0 – 0,7	0,7 – 1,25	–
1.6Z5.1203.71	20 – 3	NPT 1/2"	30	35	91,5	20	12,5 – 17,5	9 – 14	0 – 0,7	0,7 – 1,4	–
1.6Z5.3403.70	25	NPT 3/4"	36	42	105,7	20,5	16,9 – 24	12,5 – 20,5	0 – 0,7	0,9 – 1,6	0,7 – 1,4
1.6Z5.1003.70	32	NPT 1"	46	52	107	25	22 – 32,5	16,9 – 26	0 – 0,7	1,3 – 2,0	0,7 – 1,4
1.6Z5.5403.70	40	NPT 1 1/4"	55	64	120	26	28 – 39,5	22 – 33	0 – 0,7	1,3 – 2,0	0,7 – 1,4
1.6Z5.6403.70	40	NPT 1 1/2"	55	64	120	26,5	28 – 39,5	22 – 33	0 – 0,7	1,3 – 2,0	0,7 – 1,4
1.6Z5.2003.70	50	NPT 2"	65	73	144,5	27	36 – 49	28,9 – 44,4	0 – 1,0	1,5 – 2,5	1,0 – 2,0
1.6Z5.5203.70	63	NPT 2 1/2"	80	90	157,5	40	46 – 64	39,9 – 56,3	0 – 1,0	1,5 – 2,5	1,0 – 2,0
1.6Z5.3003.70	75	NPT 3"	95	107	167	41,5	57 – 78	50,5 – 68,2	0 – 1,0	1,5 – 2,5	1,0 – 2,0

EXIOS

+ BARRIER

UL-certified!

For North American specifications.

The UL-certified version is for use with Marine Shipboard cables in Hazardous Areas. The EXIOS Barrier can also be used in Zone classified Hazardous Locations.

- UL 2225 / UL 514B / CSA 22.2
- Class I; Div 1; Groups C, D
- Class II; Div 1; Groups E, F, G
- Class I; Div 2; Groups C, D
- Class II; Div 2; Groups E, F, G
- Class III
- Class I; Zone 1; AEx d IIB



Type: EXIOS BARRIER	Materials and Technical Data
Material	brass, stainless steel on request
Seals / O-Rings	silicone, VMQ
Compound	Epoxy-Putty
Clamping insert	PA 6
Armour	Metallic Armour or Screen
Temperature Range	-25° C – 85° C (-13 °F – 185 °F)
Protection	IP 66, 67 and 68 (5 bar)
UL-File	E 351373

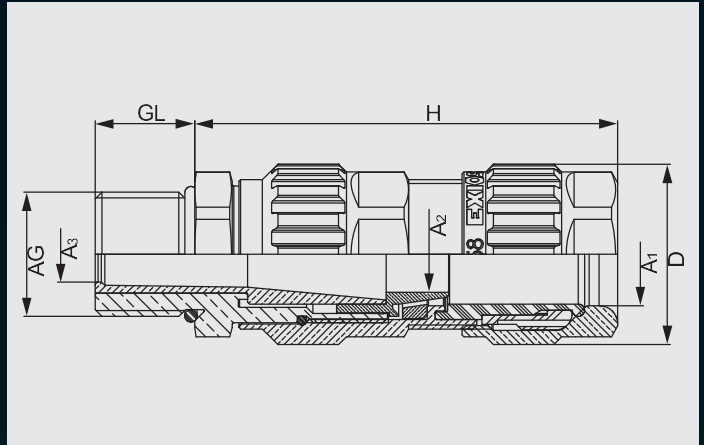

Metric brass										Armour \varnothing mm		
Number	Gland Size	AG	\varnothing mm	D mm	H max.	GL mm	\varnothing A1 mm	\varnothing A2 max. inner sheath	\varnothing A3 max. over cores	max. No. cores	Clamping ring 1	Clamping ring 2
1.6U6.2000.50	20 – 1	M20x1,5	22	27	69,5	16	6 – 12	8,2	7,9	8	0 – 0,7	0,7 – 1,25
1.6U6.2000.51	20 – 2	M20x1,5	24	29	74,3	16	9 – 16	12	8,8	10	0 – 0,7	0,7 – 1,25
1.6U6.2000.52	20 – 3	M20x1,5	30	35	80,5	16	12,5 – 20,5	14	11,5	15	0 – 0,7	0,7 – 1,4
1.6U6.2500.51	20 – 3	M25x1,5	30	35	80,5	16	12,5 – 20,5	14	11,5	15	0 – 0,7	0,7 – 1,4
1.6U6.2500.50	25	M25x1,5	36	42	91	16	16,9 – 26	20	16,4	25	0 – 0,7	0,9 – 1,6
1.6U6.3200.50	32	M32x1,5	46	52	96	16	22 – 33	26	21,4	45	0 – 0,7	1,3 – 2,0
1.6U6.4000.50	40	M40x1,5	55	64	107	16	28 – 41	33,2	27,6	70	0 – 0,7	1,3 – 2,0
1.6U6.5000.50	50	M50x1,5	65	73	131,5	16	36 – 52,6	44,2	37,5	85	0 – 1,0	1,5 – 2,5
1.6U6.6300.50	63	M63x1,5	80	90	144,5	16	46 – 65,3	56,2	47,3	120	0 – 1,0	1,5 – 2,5
1.6U6.7500.50	75	M75x1,5	95	107	154	16	57 – 78	68,2	58	150	0 – 1,0	1,5 – 2,5

NPT brass										Armour \varnothing mm		
Number	Gland Size	AG	\varnothing mm	D mm	H max.	GL mm	\varnothing A1 mm	\varnothing A2 max. inner sheath	\varnothing A3 max. over cores	max. No. cores	Clamping ring 1	Clamping ring 2
1.6U6.1200.70	20 – 2	NPT 1/2"	24	29	68,0	20	9 – 16	12	8,8	10	0 – 0,7	0,7 – 1,25
1.6U6.1200.71	20 – 3	NPT 1/2"	30	35	73,0	20	12,5 – 20,5	14	11,5	15	0 – 0,7	0,7 – 1,4
1.6U6.3400.70	25	NPT 3/4"	36	42	81,3	20,5	16,9 – 26	20	16,4	25	0 – 0,7	0,9 – 1,6
1.6U6.1000.70	32	NPT 1"	46	52	85,5	25	22 – 33	26	21,4	45	0 – 0,7	1,3 – 2,0
1.6U6.5400.70	40	NPT 1 1/4"	55	64	94,4	26	28 – 41	33,2	27,6	70	0 – 0,7	1,3 – 2,0
1.6U6.6400.70	40	NPT 1 1/2"	55	64	94,4	26,5	28 – 41	33,2	27,6	70	0 – 0,7	1,3 – 2,0
1.6U6.2000.70	50	NPT 2"	65	73	116,3	27	36 – 52,6	44,2	37,5	85	0 – 1,0	1,5 – 2,5
1.6U6.5200.70	63	NPT 2 1/2"	80	90	127,6	40	46 – 65,3	56,2	47,3	120	0 – 1,0	1,5 – 2,5
1.6U6.3000.70	75	NPT 3"	95	107	136,5	41,5	57 – 78	68,2	58	150	0 – 1,0	1,5 – 2,5

EXIOS

+ BARRIER

UL-certified!

For North American specifications.

The UL-certified version is for use with Marine Shipboard cables in Hazardous Areas. The EXIOS Barrier can also be used in Zone classified Hazardous Locations.

- UL 2225 / UL 514B / CSA 22.2
- Class I; Div 1; Groups C, D
- Class II; Div 1; Groups E, F, G
- Class I; Div 2; Groups C, D
- Class II; Div 2; Groups E, F, G
- Class III
- Class I; Zone 1; AEx d IIB



Type: EXIOS BARRIER	Materials and Technical Data
Material	nickel-plated brass
Seals / O-Rings	silicone, VMQ
Compound	Epoxy-Putty
Clamping insert	PA 6
Armour	Metallic Armour or Screen
Temperature Range	-25° C – 85° C (-13 °F – 185 °F)
Protection	IP 66, 67 and 68 (5 bar)
UL-File	E 351373

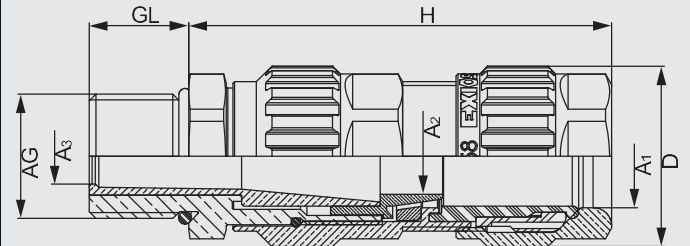

Metric nickel plated brass

Number	Gland Size	AG	ϕ mm	D mm	H max.	GL mm	∅ A1 mm	∅ A2 max. inner sheath	∅ A3 max. over cores	Armour ∅ mm		
										max. No. cores	Clamping ring 1	Clamping ring 2
1.6U6.2003.50	20 – 1	M20x1,5	22	27	69,5	16	6 – 12	8,2	7,9	8	0 – 0,7	0,7 – 1,25
1.6U6.2003.51	20 – 2	M20x1,5	24	29	74,3	16	9 – 16	12	8,8	10	0 – 0,7	0,7 – 1,25
1.6U6.2003.52	20 – 3	M20x1,5	30	35	80,5	16	12,5 – 20,5	14	11,5	15	0 – 0,7	0,7 – 1,4
1.6U6.2503.51	20 – 3	M25x1,5	30	35	80,5	16	12,5 – 20,5	14	11,5	15	0 – 0,7	0,7 – 1,4
1.6U6.2503.50	25	M25x1,5	36	42	91	16	16,9 – 26	20	16,4	25	0 – 0,7	0,9 – 1,6
1.6U6.3203.50	32	M32x1,5	46	52	96	16	22 – 33	26	21,4	45	0 – 0,7	1,3 – 2,0
1.6U6.4003.50	40	M40x1,5	55	64	107	16	28 – 41	33,2	27,6	70	0 – 0,7	1,3 – 2,0
1.6U6.5003.50	50	M50x1,5	65	73	131,5	16	36 – 52,6	44,2	37,5	85	0 – 1,0	1,5 – 2,5
1.6U6.6303.50	63	M63x1,5	80	90	144,5	16	46 – 65,3	56,2	47,3	120	0 – 1,0	1,5 – 2,5
1.6U6.7503.50	75	M75x1,5	95	107	154	16	57 – 78	68,2	58	150	0 – 1,0	1,5 – 2,5

NPT nickel plated brass

Number	Gland Size	AG	ϕ mm	D mm	H max.	GL mm	∅ A1 mm	∅ A2 max. inner sheath	∅ A3 max. over cores	Armour ∅ mm		
										max. No. cores	Clamping ring 1	Clamping ring 2
1.6U6.1203.70	20 – 2	NPT 1/2"	24	29	68,0	20	9 – 16	12	8,8	10	0 – 0,7	0,7 – 1,25
1.6U6.1203.71	20 – 3	NPT 1/2"	30	35	73,0	20	12,5 – 20,5	14	11,5	15	0 – 0,7	0,7 – 1,4
1.6U6.3403.70	25	NPT 3/4"	36	42	81,3	20,5	16,9 – 26	20	16,4	25	0 – 0,7	0,9 – 1,6
1.6U6.1003.70	32	NPT 1"	46	52	85,5	25	22 – 33	26	21,4	45	0 – 0,7	1,3 – 2,0
1.6U6.5403.70	40	NPT 1 1/4"	55	64	94,4	26	28 – 41	33,2	27,6	70	0 – 0,7	1,3 – 2,0
1.6U6.6403.70	40	NPT 1 1/2"	55	64	94,4	26,5	28 – 41	33,2	27,6	70	0 – 0,7	1,3 – 2,0
1.6U6.2003.70	50	NPT 2"	65	73	116,3	27	36 – 52,6	44,2	37,5	85	0 – 1,0	1,5 – 2,5
1.6U6.5203.70	63	NPT 2 1/2"	80	90	127,6	40	46 – 65,3	56,2	47,3	120	0 – 1,0	1,5 – 2,5
1.6U6.3003.70	75	NPT 3"	95	107	136,5	41,5	57 – 78	68,2	58	150	0 – 1,0	1,5 – 2,5

Accessories

Earth tag brass

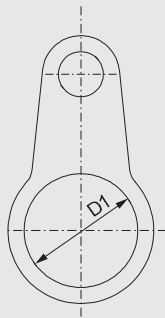

Metric	Item No.	NPT	Item No.
M 16	1.022.1600.50	1/2"	1.022.1200.70
M20	1.022.2000.50	3/4"	1.022.3400.70
M25	1.022.2500.50	1"	1.022.1000.70
M 32	1.022.3200.50	1 1/4"	1.022.5400.70
M40	1.022.4000.50	1 1/2"	1.022.6400.70
M50	1.022.5000.50	2"	1.022.2000.70
M63	1.022.6300.50	2 1/2"	1.022.5200.70
M75	1.022.7500.50	3"	1.022.3000.70

Red fibre washer



Metric	Item No.	NPT	Item No.
M 16	1.326.1600.50	1/2"	1.326.1200.70
M20	1.326.2000.50	3/4"	1.326.3400.70
M25	1.326.2500.50	1"	1.326.1000.70
M32	1.326.3200.50	1 1/4"	1.326.5400.70
M40	1.326.4000.50	1 1/2"	1.326.6400.70
M50	1.326.5000.50	2"	1.326.2000.70
M63	1.326.6300.50	2 1/2"	1.326.5200.70
M75	1.326.7500.50	3"	1.326.3000.70

PVC shroud (LSF upon request)



EXIOS Size	Item No.
20 – 1	1.802.2000.50
20 – 2	1.802.2000.51
20 – 3	1.802.2000.52
25	1.802.2500.50
32	1.802.3200.50
40	1.802.4000.50
50	1.802.5000.50
63	1.802.6300.50
75	1.802.7500.50

Accessories



Serrated Washer INOX

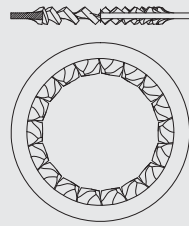

Metric	Item No.	NPT	Item No.
M16	1.329.1600.50	1/2"	1.329.1600.70
M20	1.329.2000.50	3/4"	1.329.3400.70
M25	1.329.2500.50	1"	1.329.1000.70
M32	1.329.3200.50	1 1/4"	1.329.5400.70
M40	1.329.4000.50	1 1/2"	1.329.6400.70
M50	1.329.5000.50	2"	1.329.2000.70
M63	1.329.6300.50	2 1/2"	1.329.5200.70
M75	1.329.7500.50	3"	1.329.3000.70

Locknut nickel plated brass (GM-Ms) (NPT upon request)

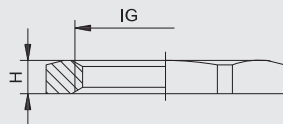
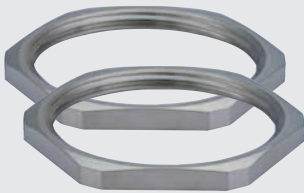

IG	H	mm	Item No. mm
M16x1,5	2,8	19	1.161.1600.50
M20x1,5	3,0	23	1.161.2000.50
M25x1,5	3,5	29	1.161.2500.50
M32x1,5	4,0	36	1.161.3200.50
M40x1,5	4,5	45	1.161.4000.50
M50x1,5	5,5	55	1.161.5000.50
M63x1,5	6,0	70	1.161.6300.50
M75x1,5	8,0	85	1.161.7500.50

